

BASIC SERIAL COMMAND

FUNCTIONAL SPECIFICATIONS

PLC-XF60A/EF60A

SANYO Electric Co., Ltd
Consumer Group
AV Company
Projector BU

CONTENTS

1. Overview	4
2. Serial Interface Specification	4
2.1. Transfer Specification	4
2.2. Connection.....	4
3. Notes for Communication	5
4. Functional Execution Command Table	6
5. Status Read Command Table	8
6. Functional Execution Command	9
6.1. Format	9
6.2. Command Pipelining	9
6.3. Transfer Example.....	9
6.4. Operation Requirements	10
6.5. POWER ON Command	11
6.6. POWER OFF Command (Quick POWER OFF)	11
6.7. INPUT 1 Command	11
6.8. INPUT 2 Command	11
6.9. INPUT 3 Command	11
6.10. INPUT 4 Command	12
6.11. INPUT 5 Command.....	12
6.12. VIDEO MUTE ON Command	12
6.13. VIDEO MUTE OFF Command.....	12
6.14. SCREEN NORMAL SIZE Command.....	12
6.15. SCREEN FULL SIZE Command	12
6.16. MENU ON Command	13
6.17. MENU OFF Command	13
6.18. DISPLAY CLEAR Command.....	13
6.19. IMAGE Command	13
6.20. D.ZOOM + Command.....	13
6.21. D.ZOOM - Command.....	13
6.22. POINTER RIGHT Command	14
6.23. POINTER LEFT Command	14
6.24. POINTER UP Command	14
6.25. POINTER DOWN Command.....	14
6.26. ENTER Command.....	14
6.27. FREEZE ON Command.....	14
6.28. FREEZE OFF Command.....	15
6.29. ZOOM + Command	15
6.30. ZOOM - Command	15

6.31.	FOCUS + Command	15
6.32.	FOCUS - Command	15
6.33.	LENS SHIFT UP Command	15
6.34.	LENS SHIFT DOWN Command	16
6.35.	LENS SHIFT LEFT Command	16
6.36.	LENS SHIFT RIGHT Command	16
6.37.	FULL LAMP MODE SET Command	16
6.38.	HALF LAMP MODE 1 SET Command	16
6.39.	HALF LAMP MODE 2 SET Command	17
6.40.	AUTO PC ADJ. Command	17
6.41.	PRESENTATION TIMER Command	17
6.42.	KEYSTONE ↑ Command	17
6.43.	KEYSTONE ↓ Command	17
6.44.	KEYSTONE → Command	18
6.45.	KEYSTONE Command	18
7.	Status Read Command	19
7.1.	Format	19
7.2.	Transfer Example	19
7.3.	Status Read Command	20
7.4.	Input Mode Read Command	23
7.5.	Lamp Time Read Command	23
7.6.	Setting Read Command	23
7.7.	Temp Read Command	24
7.8.	Lamp Mode Read Command	24
7.9.	PC Type Read Command	25
7.10.	Status 2 Read Command	25
8.	Command with Address Specification	26
8.1.	Overview	26
8.2.	Functional Execution Command with Address	27
8.3.	Status Read Command with Address	28

1 Overview

- 1.1 These specifications define projector control commands for PLC-XF60A/EF60A.
- 1.2 The projector control commands are used to control a projector through RS-232C from a computer.
- 1.3 When using commands with address, see [8. Command with Address Specification].

2 Serial Interface Specification

2.1 Transfer Specification

Items	Specification
Synchronous system	Asynchronous
Transmission Speed	9600 / 19200
Data Length	8 bit
Parity	N/A
Stop Bit	1
Flow Control	N/A

- 1) Transmission speed: initial setting value is 19200.
- 2) Transmission speed can be changed in "SPECIAL" – "RS-232C" in the menu.

2.2 Connection

Dedicated serial cable that meets the following specifications must be used for a connection to a computer and a projector.

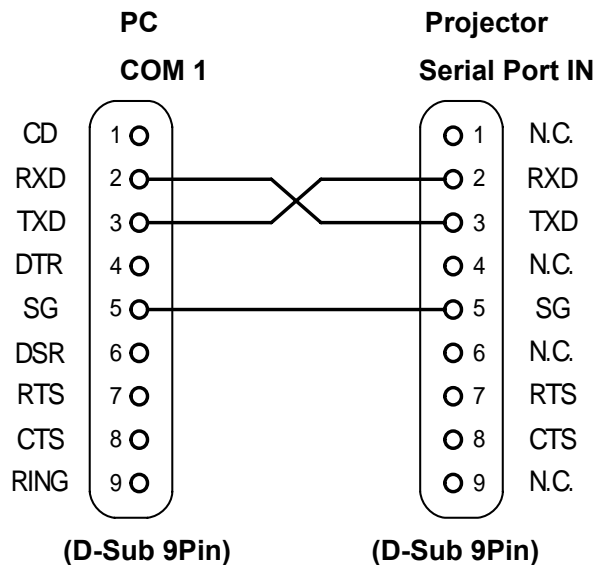

Connect COM port of a computer to SERIAL PORT IN of a projector.

COM Port (COM1 or COM2) of a computer is specified by control software of a computer.

3 Notes for Communication

- 3.1 The projector command is defined as one command/one line that starts with "C" and ends with carriage return (0x0D).
- 3.2 When the projector receives carriage return, it starts decoding.
- 3.3 There are two types of commands: Functional Execution Commands and Status Read Commands.
Example of Functional Execution Command: "C05" [CR]
Example of Status Read Command: "CR0" [CR]
- 3.4 It clears the information of buffer as below.
3.4.1 When the projector receives LF (0x0A) or EOF (0x1A).
3.4.2 When it takes more than one second to receive one command.
(Until the projector returns carriage return since it has received the first data.)
- 3.5 When control command pipelining, wait the interval of time after the response as below.
3.8 [VOLUME +/-] [ZOOM UP/DOWN] [FOCUS UP/DOWN] [LENS SHIFT UP/DOWN/ LEFT/ RIGHT] Commands \longrightarrow 100ms
3.5.2 Other Commands \longrightarrow 500ms
- 3.6 When Status Read command pipelining, wait at least 500ms after the response.
- 3.7 Do not issue any command before receiving the response except there is no response for 5 seconds.
- 3.8 It takes about 7 seconds for the internal initialization after plugging in AC. During this time, it cannot process commands. Do not issue any command.
- 3.9 For 7 seconds after Power ON from Standby, the projector receives a command and returns the response but does not execute it because of the internal initialization or Lamp processing. However, Status Read Commands are carried out 500 ms after receiving the response to Power ON command.
- 3.10 About the performance during Count Down and Cooling Down:
When receiving a command during Count Down after Power ON or Cooling Down after Power OFF, the projector returns the response but does not carry it out. However, Status Read Commands are carried out.
- 3.11 The performance for switching Input:
It takes 5 seconds to switch Input after receiving the command. When receiving the command during this time, it is not executed. However, Status Read Commands are carried out 500ms after it receives the response to Switching Input command.
- 3.12 The number of character of response to Status Read Commands depends on commands. Please see [7. Status Read Commands] for the details.
- 3.13 Characters for commands must be Capital (A - Z).

4 . Functional Execution Command Table

Command	Item	Command	Item
C00	POWER ON	C20	
C01	POWER OFF (QUICK POWER OFF)	C21	
C02		C22	
C03	INPUT 5	C23	
C04		C24	
C05	INPUT 1	C25	
C06	INPUT 2	C26	
C07	INPUT 3	C27	IMAGE (Toggle)
C08	INPUT 4	C28	
C09		C29	
C0A		C2A	
C0B		C2B	
C0C		C2C	
C0D	VIDEO MUTE ON	C2D	
C0E	VIDEO MUTE OFF	C2E	
C0F	SCREEN NORMAL SIZE	C2F	
C10	SCREEN FULL SIZE	C30	D.ZOOM + *1
C11		C31	D.ZOOM - *1
C12		C32	
C13		C33	
C14		C34	
C15		C35	
C16		C36	
C17		C37	
C18		C38	
C19		C39	
C1A		C3A	POINTER RIGHT
C1B		C3B	POINTER LEFT
C1C	MENU ON	C3C	POINITER UP
C1D	MENU OFF	C3D	POINITER DOWN
C1E	DISPLAY CLEAR	C3E	
C1F		C3F	ENTER

“ ” means “No Function”.

Note) *1 = Not compatible with Option Control No.5 (Available for Option Control No.06 or later).

Command	Item	Command	Item
C40		C80	
C41		C81	
C42		C82	
C43	FREEZE ON	C83	
C44	FREEZE OFF	C84	
C45		C85	
C46	ZOOM -	C86	
C47	ZOOM +	C87	
C48		C88	
C49		C89	AUTO IMAGE
C4A	FOCUS -	*C8A	PRESENTATION TIMER *1
C4B	FOCUS +	C8B	
C4C		C8C	
C4D		C8D	
C4E		*C8E	KEystone ↑ *1
C4F		*C8F	KEystone ↓ *1
C50		*C90	KEystone → *1 *2
C51		*C91	KEystone ← *1 *2
C52		C92	
C53		C93	
C54		C94	
C55		C95	
C56		C96	
C57		C97	
C58		C98	
C59		C99	
C5A		C9A	
C5B		C9B	
C5C		C9C	
C5D	LENS SHIFT UP	C9D	
C5E	LENS SHIFT DOWN	C9E	
C5F	LENS SHIFT LEFT	C9F	
C60	LENS SHIFT RIGHT		
C61			
C62			
C70	FULL LAMP MODE (4 Lamp)		
C71	HALF LAMP MODE (2 Lamp: 1-4)		
C72	HALF LAMP MODE (2 Lamp: 2-3)		

“ ” means “No Function”.

Note) *1 = Not compatible with Option Control No.5 (Available for Option Control No.06 or later).

*2 = Not available for PLC-EF60A because horizontal keystone function is not installed.

5 . Status Read Command Table

Command	Item	Memo
CR0	Status Read	
CR1	Input Mode Read	
CR2		
CR3	Lamp Time Read	
CR4	Setting Read	
CR5		
CR6	Temp Read	
CR7	Lamp Mode Read	
CR8		
CR9	PC Type Read	
CRA	Status 2 Read	
CRB		
CRC		

“ ” means “No Function”.

6 . Functional Execution Command

6.1 Format

6.1.1 PC issues a command in format as below.

“C” **COMMAND** [CR]

Command: two characters (See Basic Functional Execution Command Table)

6.1.2 A projector decodes the received data and returns a response after being ready to receive next command.

[ACK] [CR]: (0x06, 0x0D) When receives Functional Execution Commands.

“?” [CR]: When the received data cannot be decoded.

6.2 Command Pipelining

When some functions need the command pipelining, the performance is the same as that of the remote control.

6.2.1 System: issue any command every 100 ms.

6.2.2 When receiving the appropriate command, the function is executed for 120 ms from the moment.

6.2.3 When receiving the same command continuously within 120 ms, the function is executed for another 120 ms from the moment.

6.2.4 When there is no incoming command after 120 ms, the execution of pipelining is stopped.

6.2.5 When the projector receives other incoming commands within 120ms, the execution of pipelining is stopped.

6.3 Transfer Example

Select Input 3 for the projector with Basic Command.

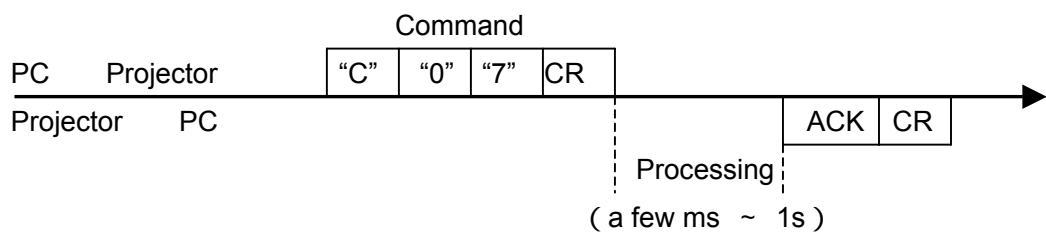

6.4 Operation Requirements

When the projector's status is as below, Functional Execution Commands are limited.

(Status Read Commands are available in this status.)

Projector Status	Available Functional Execution Commands
Standby Mode	C00: POWER ON
Processing Countdown	C00: POWER ON (Countdown is terminated)
Processing Cooling Down	NONE
Cooling Down due to Abnormal Temperature	NONE
Abnormal Temperature Status	NONE
Switching Mode	NONE
Processing Power Save / Cooling Down	NONE
Processing Shutter Management / Cooling Down	NONE
Power Save Status	C00: POWER ON C01: POWER OFF

Note) When the status is above, even if the projector receives other commands, it returns **[ACK] [CR]**.

6.5 POWER ON Command

COMMAND	"C00" [CR]	
Detail	<p>Power ON When already Power is ON, no need to do. When sending this command during processing Countdown, Countdown is terminated. Note) The response of acceptance does not always mean that the status has already moved to Power ON. Ex: When the temperature approaches abnormal status after returning the response [ACK] [CR] to the command "C00". Therefore, it needs to get the projector status with Status Read command.</p>	
Response	Acceptable	[ACK] [CR]
	Unacceptable	"?" [CR]

6.6 POWER OFF Command (QUICK POWER OFF)

COMMAND	"C01" [CR]	
Detail	<p>Power OFF (Standby) When Power is OFF with ON-OFF button of the projector and remote control, "Power OFF" is displayed. However, as soon as this command is sent, Quick Power OFF is executed.</p>	
Response	Acceptable	[ACK] [CR]
	Unacceptable	"?" [CR]

6.7 INPUT 1 Command

COMMAND	"C05" [CR]	
Detail	Select Slot 1 Input.	
Response	Acceptable	[ACK] [CR]
	Unacceptable	"?" [CR]

6.8 INPUT 2 Command

COMMAND	"C06" [CR]	
Detail	Select Slot 2 Input	
Response	Acceptable	[ACK] [CR]
	Unacceptable	"?" [CR]

6.9 INPUT 3 Command

COMMAND	"C07" [CR]	
Detail	Select Slot 3 Input	
Response	Acceptable	[ACK] [CR]
	Unacceptable	"?" [CR]

6.10 INPUT 4 Command

COMMAND	"C08" [CR]	
Detail	Select Slot 4 Input Note) When there is no card inserted to Slot 4, it is not executed.	
Response	Acceptable	[ACK] [CR]
	Unacceptable	"?" [CR]

6.11 INPUT 5 Command

COMMAND	"C03" [CR]	
Detail	Select Slot 5 Input Note) When there is no card inserted to Slot 5, it is not executed.	
Response	Acceptable	[ACK] [CR]
	Unacceptable	"?" [CR]

6.12 VIDEO MUTE ON Command

COMMAND	"C0D" [CR]	
Detail	Black out an image by releasing Shutter The same operation as "Shutter" button of the projector and remote control for Shutter ON, but it does not work for Shutter OFF.	
Response	Acceptable	[ACK] [CR]
	Unacceptable	"?" [CR]

6.13 VIDEO MUTE OFF Command

COMMAND	"C0E" [CR]	
Detail	Restore an image by opening Shutter The same operation as "Shutter" button of the projector and remote control for Shutter OFF, but it does not work for Shutter ON.	
Response	Acceptable	[ACK] [CR]
	Unacceptable	"?" [CR]

6.14 SCREEN NORMAL SIZE Command

COMMAND	"C0F" [CR]	
Detail	Set screen size to Normal	
Response	Acceptable	[ACK] [CR]
	Unacceptable	"?" [CR]

6.15 SCREEN FULL SIZE Command

COMMAND	"C10" [CR]	
Detail	Set screen size to Full screen	
Response	Acceptable	[ACK] [CR]
	Unacceptable	"?" [CR]

6.16 MENU ON Command

COMMAND	"C1C" [CR]	
Detail	Display Menu of On Screen Display	
Response	Acceptable	[ACK] [CR]
	Unacceptable	"?" [CR]

6.17 MENU OFF Command

COMMAND	"C1D" [CR]	
Detail	Clear Menu of On Screen Display	
Response	Acceptable	[ACK] [CR]
	Unacceptable	"?" [CR]

6.18 DISPLAY CLEAR Command

COMMAND	"C1E" [CR]	
Detail	Clear the On Screen Display Clear all On Screen Display unconditionally.	
Response	Acceptable	[ACK] [CR]
	Unacceptable	"?" [CR]

6.19 IMAGE Command

COMMAND	"C27" [CR]	
Detail	Switch Image Setting	
Response	Acceptable	[ACK] [CR]
	Unacceptable	"?"[CR]

6.20 D.ZOOM + Command

COMMAND	"C30" [CR]	
Detail	Enter Digital Zoom Mode and expand image size	
Response	Acceptable	[ACK] [CR]
	Unacceptable	"?" [CR]

6.21 D.ZOOM – Command

COMMAND	"C31" [CR]	
Detail	Enter Digital Zoom Mode and compress image size	
Response	Acceptable	[ACK] [CR]
	Unacceptable	"?" [CR]

6.22 POINTER RIGHT Command

COMMAND	"C3A" [CR]	
Detail	Move Pointer of On-Screen Display Menu to the right This command performs the same operation as tapping the right side of control pad on the projector and remote control.	
Response	Acceptable	[ACK] [CR]
	Unacceptable	"?" [CR]

6.23 POINTER LEFT Command

COMMAND	"C3B" [CR]	
Detail	Move Pointer of On Screen Display Menu to the left The same operation as tapping the left side of the control pads on the projector and remote control.	
Response	Acceptable	[ACK] [CR]
	Unacceptable	"?" [CR]

6.24 POINTER UP Command

COMMAND	"C3C" [CR]	
Detail	Move Up Pointer of On Screen Display Menu The same operation as tapping the upper side of the control pads on the projector and remote control.	
Response	Acceptable	[ACK] [CR]
	Unacceptable	"?" [CR]

6.25 POINTER DOWN Command

COMMAND	"C3D" [CR]	
Detail	Move Down Pointer of On Screen Display Menu The same operation as tapping the downside of the control pads on the projector and remote control.	
Response	Acceptable	[ACK] [CR]
	Unacceptable	"?" [CR]

6.26 ENTER Command

COMMAND	"C3F" [CR]	
Detail	The same operation as "SELECT" button of the projector and remote control.	
Response	Acceptable	[ACK] [CR]
	Unacceptable	"?" [CR]

6.27 FREEZE ON Command

COMMAND	"C43" [CR]	
Detail	Freeze picture on-screen The same operation as "FREEZE" button of the remote control for Freeze ON, but it does not work for Freeze OFF.	
Response	Acceptable	[ACK] [CR]
	Unacceptable	"?" [CR]

6.28 FREEZE OFF Command

COMMAND	"C44" [CR]	
Detail	Cancel Freeze function The same operation as "FREEZE" button of the remote control for Freeze Off, but it does not work for Freeze ON.	
Response	Acceptable	[ACK] [CR]
	Unacceptable	"?" [CR]

6.29 ZOOM + Command

COMMAND	"C47" [CR]	
Detail	Make screen image larger The same operation as "ZOOM +" button of the remote control.	
Response	Acceptable	[ACK] [CR]
	Unacceptable	"?" [CR]

6.30 ZOOM – COMMAND

COMMAND	"C46" [CR]	
Detail	Make screen image smaller The same operation as "ZOOM –" button of the remote control.	
Response	Acceptable	[ACK] [CR]
	Unacceptable	"?" [CR]

6.31 FOCUS + Command

COMMAND	"C4B" [CR]	
Detail	Adjust focus of screen image (sharp and clear) with a long-focal-length () (the lens direction is backward) The same operation as "FOCUS +" button of the remote control.	
Response	Acceptable	[ACK] [CR]
	Unacceptable	"?" [CR]

6.32 FOCUS – Command

COMMAND	"C4A" [CR]	
Detail	Adjust focus of screen image (sharp and clear) with a short-focal-length (the lens direction is forward) The same operation as "FOCUS –" button of the remote control.	
Response	Acceptable	[ACK] [CR]
	Unacceptable	"?" [CR]

6.33 LENS SHIFT UP Command

COMMAND	"C5D" [CR]	
Detail	Move screen image Up by Lens Shift function	
Response	Acceptable	[ACK] [CR]
	Unacceptable	"?" [CR]

6.34 LENS SHIFT DOWN Command

	"C5E" [CR]	
Detail	Move screen image Down by Lens Shift function	
Response	Acceptable	[ACK] [CR]
	Unacceptable	"?" [CR]

6.35 LENS SHIFT LEFT Command

COMMAND	"C5F" [CR]	
Detail	Move screen image to the left by Lens Shift function	
Response	Acceptable	[ACK] [CR]
	Unacceptable	"?" [CR]

6.36 LENS SHIFT RIGHT Command

COMMAND	"C60" [CR]	
Detail	Move screen image to the right by Lens Shift function	
Response	Acceptable	[ACK] [CR]
	Unacceptable	"?" [CR]

6.37 FULL LAMP MODE SET Command

COMMAND	"C70" [CR]	
Detail	Set all lamps to ON When switching to 1 lamp from all lamps then to all lamps again, or switching to all lamps from 1 lamp then to 1 lamp again, it is unable to switch for 90 seconds for the light preparation.	
Response	Acceptable	[ACK] [CR]
	Unacceptable	"?" [CR]

6.38 HALF LAMP MODE 1 SET Command

COMMAND	"C71" [CR]	
Detail	Set to HALF LAMP Mode (1 lamp mode) Lamp No.1 is set. Usually when Half Lamp Mode is set, the projector automatically chooses lamps, but with this command, Lamp No.1 is first chosen. This function can be used for White Balance adjustment and color correction. When switching to 1 lamp from all lamps then to all lamps again, or switching to all lamps from 1 lamp then to 1 lamp again, it is unable to switch for 90 seconds for the light preparation.	
Response	Acceptable	[ACK] [CR]
	Unacceptable	"?" [CR]

6.39 HALF LAMP MODE 2 SET Command

COMMAND	"C72" [CR]	
Detail	Set to HALF LAMP Mode (1 lamp mode) Lamp No.2 is set. Usually, when Half Lamp Mode is set, the projector automatically chooses lamps, but with this command, Lamp No.2 is first chosen. This function can be used for White Balance adjustment and color correction. When switching to 1 lamp from all lamps then to all lamps again, or switching to all lamps from 1 lamp then to 1 lamp again, it is unable to switch for 90 seconds for the light preparation.	
Response	Acceptable	[ACK] [CR]
	Unacceptable	"?" [CR]

6.40 AUTO PC ADJ. Command

	"C89" [CR]	
Detail	Execute AUTO PC ADJ. function This command works the same as "AUTO PC" button of the remote control. While Auto PC Adj. is working and a computer issues another command, Auto PC Adj. stops. This is the same function as "AUTO PC" button of the remote control.	
Response	Acceptable	[ACK] [CR]
	Unacceptable	"?" [CR]

6.41 PRESENTATION TIMER Command

	"C8A" [CR]	
Detail	Start timer to count time for presentation This command works the same as "P-TIMER" button of the remote control.	
Response	Acceptable	[ACK] [CR]
	Unacceptable	"?" [CR]

6.42 KEYSTONE ↑ Command

COMMAND	"C8E" [CR]	
Detail	Correct keystone distortion by reducing upper part of image	
Response	Acceptable	[ACK] [CR]
	Unacceptable	"?" [CR]

6.43 KEYSTONE ↓ Command

COMMAND	"C8F" [CR]	
Detail	Correct keystone distortion by reducing lower part of image.	
Response	Acceptable	[ACK] [CR]
	Unacceptable	"?" [CR]

6.44 **KEYSTONE** → **Command**

COMMAND	"C90" [CR]	
Detail	Correct keystone distortion by reducing right part of image Not available for PLC-EF60A as this is not installed.	
Response	Acceptable	[ACK] [CR]
	Unacceptable	"?" [CR]

6.45 **KEYSTONE** ← **Command**

COMMAND	"C91" [CR]	
Detail	Correct keystone distortion by reducing left part of image. Not available for PLC-EF60 A as this is not installed.	
Response	Acceptable	[ACK] [CR]
	Unacceptable	"?" [CR]

7 . Status Read Command

7.1 Format

7.1.1 PC issues commands in format as below.

"CR" [COMMAND] [CR]

Command: one character (See Status Read Command Table)

7.1.2 When a projector receives the appropriate command, it returns a character line as the required data.

[Required Data] [CR]

Required Data: A character line (See Status Read Command Table)

7.1.3 When the received data cannot be decoded, the projector returns "?" [CR].

7.2 Transfer Example

Get input mode for projector by basic commands.

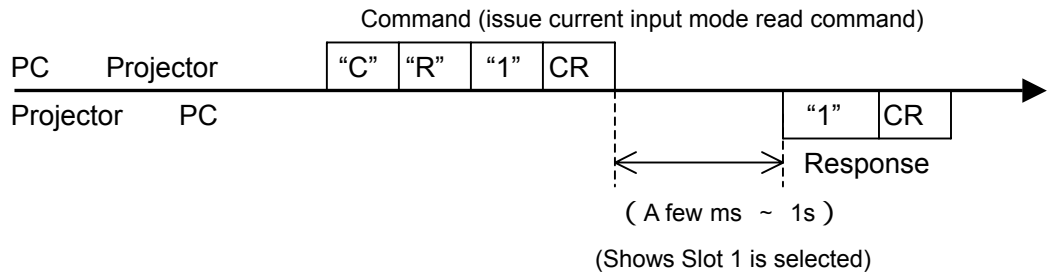

7.3 Status Read Command

COMMAND	"CR0" [CR]	
Detail	Get the projector status	
Response	Acceptable	"%1" [CR]
	%1	"00" = Power ON "80" = Standby "40" = Processing Countdown "20" = Processing Cooling Down "10" = Power Failure "28" = Processing Cooling Down due to abnormal temperature "88" = Standby after Cooling Down due to abnormal temperature "02" = Invalid RS-232C Command "24" = Processing Power Save / Cooling Down "04" = Power Save "21" = Processing Cooling Down after Off due to lamp failure "81" = Standby after Cooling Down due to lamp failure "2C" = Processing Cooling Down after Off due to Shutter management "8C" = Standby after Cooling Down due to Shutter management
	Unacceptable	"?" [CR]

【Details for Response】

7.3.1 "00" [CR]

Status: Power ON
 Normal image is on-screen.

7.3.2 "80" [CR]

Status: Standby
 When the status is Standby, Status Read Commands are always acceptable, but Functional Execution Commands are not acceptable except Power ON Command.

7.3.3 "40" [CR]

Status: Processing Countdown
 When "Display" in Setting menu is ON and POWER ON is executed, it starts processing Countdown.
 When "Display" in Setting menu is OFF, processing Countdown is canceled and the status moves to Power ON.

7.3.4 "20" [CR]

Status: Processing Cooling Down
 When the status is Power ON and Power OFF Command ("C01"[CR]) is executed, it moves to Cooling Down. This status automatically moves to Standby when lamp is turned off and the fan spin finishes after about 90 seconds. (The fan spin time depends on models.)
 This function is used to cool down lamps and other optical parts, and is quite important to projector's liability. During this time, Functional Execution Commands are invalid.

7.3.5 **“10” [CR]**

Status: Power Failure

When the power supply voltage inside the projector reaches abnormal status, the projector is automatically turned off. The projector returns “10”[CR], which shows it moves to Power OFF status due to power failure.

Fan also stops unlike Cooling Down status.

7.3.6 **“28” [CR]**

Status: Processing Cooling Down due to abnormal temperature

When the inside temperature becomes abnormally high, it automatically starts Cooling Down. Response for this status is “28”[CR].

Even if the temperature decreases during this process, Cooling Down is executed and it moves to Standby mode. The response command “28” is hold.

7.3.7 **“88” [CR]**

Status: Standby after Cooling Down due to abnormal temperature

The projector status is restored from abnormal temperature.

When the status moves to Standby after Cooling Down due to abnormal temperature, it returns “88” [CR].

This shows the status turns to Standby because of abnormal temperature.

This status is maintained until next operation is done. When Power ON is executed, the information of abnormal temperature is canceled and normal operation is executed.

7.3.8 **“02” [CR]**

Status: RS-232C Commands are invalid.

When receiving this response, re-send Status Read Command.

7.3.9 **“24” [CR]**

Status: Processing Power Save / Cooling Down

Power management function in the Setting menu works and the status goes to Power Save / Cooling Down.

During this time, Functional Execution Commands are invalid. (not executed.)

The status moves to Power Save after the operation of Cooling Down for set hours.

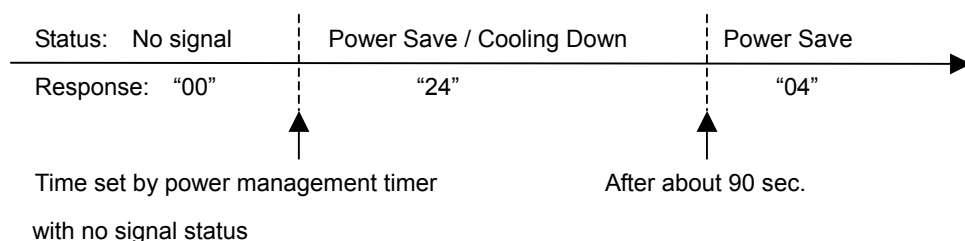

7.3.10 **“04” [CR]**

Status: Power Save

This shows it moves to Power Save status by Power management function in the Setting menu.

7.3.11 **“21” [CR]**

Status: Processing Cooling Down after OFF due to lamp failure

When a projector is turned off because of lamp failure, it starts Cooling Down. It returns “21” [CR].

The response command “21” [CR] is maintained during Cooling Down.

7.3.12 **“81” [CR]**

Status: Standby after Cooling Down due to lamp failure

The projector’s status is restored from lamp failure.

When the status moves to Standby after Cooling Down due to lamp failure, it returns “81”.

This shows the status turns to Standby because of lamp failure. This status stays until next operation is done.

When Power ON is executed, the information of lamp failure is canceled and normal operation is executed.

7.3.13 **“2C” [CR]**

Status: Processing Cooling Down after Off due to Shutter management

This shows the status is Cooling Down because of Shutter management function in the Setting menu.

During this time, Functional Execution Commands are invalid (not executed).

7.3.14 **“8C” [CR]**

Status: Standby after Cooling Down due to Shutter management

When the status moves to Standby after Cooling Down due to Shutter management, it returns “8C” [CR]. This shows the status turns to Standby because of Shutter management.

This status is maintained until next operation is done.

When Power ON is executed, the information of Shutter management is canceled and normal operation is executed.

7.4 Input Mode Read Command

COMMAND	"CR1" [CR]	
Detail	Get the selected Input.	
Response	Acceptable	"%1" [CR]
	%1	"1" = Input 1 is selected. "2" = Input 2 is selected. "3" = Input 3 is selected. "4" = Input 4 is selected. "5" = Input 5 is selected.
	Unacceptable	"?" [CR]

7.5 Lamp Time Read Command

COMMAND	"CR3" [CR]	
Detail	Get the total lamp running hours.	
Response	Acceptable	"%1_%2" [CR]
	%1, %2	There is lamp 1 data, one space, and lamp 2 data. The total lamp running hours is showed as 5-digit number. %1 = lamp No.1 %2 = lamp No.2 Example: "00410_00410"[CR] Lamp No.1 = 410 Hours Lamp No.2 = 410 Hours
	Unacceptable	"?" [CR]

7.6 Setting Read Command

COMMAND	"CR4" [CR]	
Detail	Get the screen setting status such as Ceiling / Rear.	
Response	Acceptable	"%1" [CR]
	%1	"11"[CR] = Normal Screen Setting "10"[CR] = Picture is top/bottom reversed. (Status: Rear & Ceiling ON) "01"[CR] = Picture is left/right reversed. (Status: Rear ON) "00"[CR] = Picture is top/bottom and left/right reversed. (Status: Ceiling ON)
	Unacceptable	"?" [CR]

7.7 Temp. Read Command

COMMAND	"CR6" [CR]	
Detail	Get the temperature data inside a projector. With some temperature sensors installed in the projector, it is possible to get all the temperature at once.	
Response	Acceptable	"%1_%2_%3_%4" [CR]
	%1 %2 %3 %4	<p>%1 = Temperature of sensor 1 (External temp.) %2 = Temperature of sensor 2 (Internal temp. 1) %3 = Temperature of sensor 3 (Internal temp. 2) %4 = Temperature of sensor 4 ("_XX.X" Fixed)</p> <p>Temperature data is shown as "00.0".</p> <p>When the temperature sinks to -, the first character is "-" like "-05.5" [CR].</p> <p>When no temperature data returns due to hardware problems, the first character is "E" like "E00.0" [CR].</p> <p>When the status is Standby or it is 10 seconds after Power ON, temperature may approach the abnormal status due to ballast lamp's residual heat depending on projectors. So, when the status is Standby or it is 10 seconds after Power On, the process for the abnormal temperature is not executed. The temperature data is "□----" at the time.</p> <p>As %4 indicates the sensor 4 data which can only detect two states of "Normal" or "Abnormal", the temperature is shown as "□XX.X".</p> <p>With some temperature sensors installed, the projector sends commands continuously. "□31.5 □□35.2 □□38.5 □□XX.X" [CR] There is the sensor 1 data, one space, and the sensor 2 data...</p>
	Unacceptable	"?" [CR]

7.8 Lamp Mode Read Command

COMMAND	"CR7" [CR]	
Detail	Get Lamp Mode for multiple-lamp projector. It is possible to get Lamp Mode for multiple-lamp projector. When lamp failure occurs, it is also possible to get its information.	
Response	Acceptable	"%1" [CR]
	%1	<p>Example: "0F"[CR] First digit indicates Lamp Mode. 0 = 2 lamps Mode 1 = 1 lamp Mode (Lamp No.1) 2 = 1 lamp Mode (Lamp No.2)</p> <p>Second digit indicates if the lamp is ON or OFF. Data is shown as "0-9" and "A-F" which is regarded as 4 bit data. Assign each bit to each lamp data. Example: 0 = ALL OFF 1 = No.1 is ON, the other is OFF 2 = No.2 is ON, the other is OFF 3 = ALL ON</p>
	Unacceptable	"?" [CR]

7.9 PC Type Read Command

COMMAND	"CR9" [CR]	
Detail	Get the currently displayed PC Type.	
Response	Acceptable	"%1" [CR]
	%1	"Stand_by" ----- Standby "AV_Mode" ----- AV Mode Current Table such as "UXGA_1". ----- PC Mode "Mode1 ~ 50" ----- Mode1 ~ 20 "Go_PC_adj." ----- Auto "No_signal" ----- No signal
	Unacceptable	"?" [CR]

7.10 Status 2 Read Command

COMMAND	"CRA" [CR]	
Detail	Get the operating status of Video & Volume Mute	
Response	Acceptable	"%1" [CR]
	% 1	<p>Return hexadecimal digit of 1 byte as a two-figure character line. Hexadecimal digit is regarded as eight bits and each bit is defined as below.</p> <p style="text-align: center;">+ + + + + + + + + +</p> <p style="margin-left: 40px;"> Bit 0 : Video Mute ON/OFF (ON = 1, OFF = 0) Bit 1 : Sound Mute ON/OFF (ON = 1, OFF = 0) Bit 2 : Spare Bit 3 : Spare Bit 4 : Spare Bit 5 : Spare Bit 6 : Spare Bit 7 : No Signal=1, Signals=0 </p> <p>Example:</p> <ol style="list-style-type: none"> 1) When Video Mute is ON (Shutter is ON) : + + + + + + + + 1 → "01", "03" 2) When Video Mute is OFF (Shutter is ON) : + + + + + + + + 0 → "00", "02" 3) When there is no signal : 1 + + + + + + + + 1 → "80", "81" <p>When in Standby mode or processing Cooling Down, it returns "FF" [CR].</p>
	Unacceptable	"?" [CR]

8 . Command with Address Specification

8.1 Overview

- 8.1.1 Commands with address are used to remotely control multiple projectors through RS-232C by one computer.
- 8.1.2 The command with address is defined one command/one line that starts with "A" and ends with carriage return (0x0D).
- 8.1.3 When a projector receives carriage return (0x0D), it starts decoding.
- 8.1.4 This command is represented Basic Command or Expand Command with address such as "A001".
- (Ex) Functional Execution Command
"A001C05"[CR]
- (Ex) Status Read Command
"A001CR0"[CR]
- 8.1.5 Projector has a function to set up its address in "SPECIAL" – "RS-232C" – "Projector ID" in the menu.
- Initial setting is "No. 001"
Possible range is "001" to "999"
- 8.1.6 It clears the received buffer in the case as below.
- When receiving LF (0x0A) or EOF (0x1A)
 - When it takes more than one second to receive one command.
- (When it takes more than 1 second to receive carriage return since the projector has received the first data.)
- 8.1.7 Wait the interval up to 60 ms for the response.

8.2 Functional Execution Command with address

8.2.1 Format

- 1) PC issues commands in format as below:

"A" Address "C" Command [CR]

or

"C" Address "CF□" Command "□" Parameter [CR]

Address: 3-digit number ("001"- "999")

Commands with "FFF" as the address are available for all projectors.

Command: Character line (See Basic or Expand Serial Commands)

- 2) The only projector with the appropriate address decodes received commands, and when it is ready to receive next commands, it returns the response.

[ACK] [CR]: When receiving Functional Execution Command (0x06, 0x0D)

"?" [CR]: When the received data cannot be decoded

However, when address is "FFF", it executes the function but does not return the response.

8.2.2 Command Pipelining

When it needs command pipelining, the operation is the same as the remote control.

- 1) PC issues commands every 100 ms
- 2) When receiving the appropriate command, projector executes it continuously for 120 ms.
- 3) When receiving the same command in 120 ms, the projector executes it continuously for another 120 ms from the moment.
- 4) When there is no command after 120 ms, this execution is stopped.
- 5) When receiving other commands in 120 ms, this execution is stopped.

8.3 Status Read Command with Address

8.3.1 Format

1) PC issues commands in format as below:

"A" Address "CR" COMMAND [CR]

or

"A" Address "CR_" COMMAND [CR]

Address: 3 digits number ("001"- "999")

Command: Character line (See Basic Command or Expand Command)

2) The only projector with the appropriate address decodes received commands and returns the character line as the required data.

Required Data [CR]

Required Data: Character Line (See Basic Status Read Command)

3) When the received data cannot be decoded, it returns "?" [CR].